

7.0-13.0 GHz GaAs MMIC 6-Bit Phase Shifter

Features

- ✕ 6-Bit Phase Shifter
- ✕ LVCMOS/TTL Compatible Digital Control
- ✕ 5.625° Least Significant Bit (LSB)
- ✕ 25 dBm P1dB Input Compression
- ✕ 100% On-Wafer RF and DC Testing
- ✕ 100% Visual Inspection to MIL-STD-883 Method 2010

General Description

Mimix Broadband's 7.0 – 13.0 GHz phase shifter is digitally controlled with 6-Bit operation and a LSB of 5.625°. The device uses a single supply voltage of -7.5V and digital control voltage of 0 to 5V. This MMIC uses Mimix Broadband's GaAs PHEMT device technology, and is based upon optical gate lithography to ensure high repeatability and uniformity. The chip has surface passivation to protect and provide a rugged part with backside via holes and gold metallization to allow either a conductive epoxy or eutectic solder die attach process. The device is well suited for Beamforming, EW Receivers, Military & Weather Radar, and SATCOM applications.

Chip Device Layout

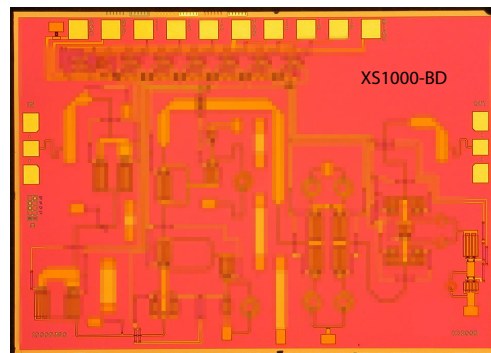

Absolute Maximum Ratings

Supply Voltage (Vss)	-15.0 VDC
Supply Current (Iss)	12.0 mA
Input Power (Pin)	+30.0 dBm
Storage Temperature (Tstg)	-65 to +165 °C
Operating Temperature (Ta)	-55 to +85 °C

Electrical Characteristics (Ambient Temperature T = 25 °C)

Parameter	Units	Min.	Typ.	Max.
Frequency Range (f)	GHz	7.0	-	13.0
Insertion Loss @ 10 GHz (S21), Reference Level	dB	-	6.2	-
Input Return Loss (S11), All States	dB	-	15.0	-
Output Return Loss (S22), All States	dB	-	15.0	-
Input 1-dB Compression Point (IP1dB)	dBm	-	25	-
RMS Phase Error	deg	-	2.5	-
RMS Attenuation Error	dB	-	0.9	-
Control Voltage (Vc1,2,3,4,5,6 - High)	VDC	2.0	-	5.0
Control Voltage (Vc1,2,3,4,5,6 - Low)	VDC	0.0	-	0.8
Source Supply Voltage (Vss)	VDC	-	-7.5	-
Supply Current (Iss) (Vss=-7.5V, Typical)	mA	-	10	-

7.0-13.0 GHz GaAs MMIC 6-Bit Phase Shifter

Measurements

XS1000-BD, V_{ss}=-7.5V, All States

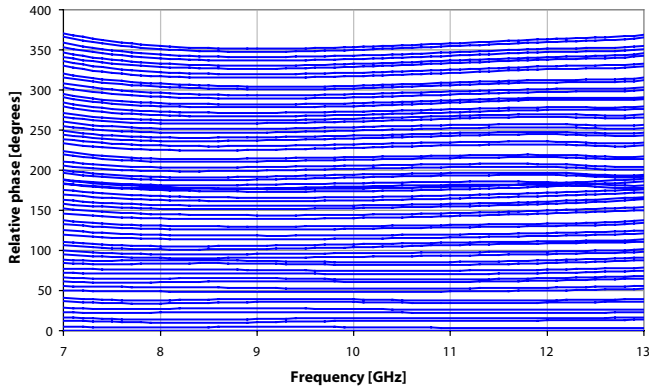

XS1000-BD, V_{ss}=-7.5V, Ref State

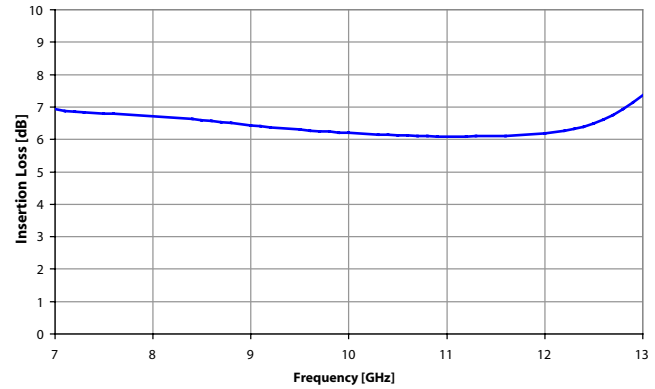

XS1000-BD, V_{ss}=-7.5V, All States

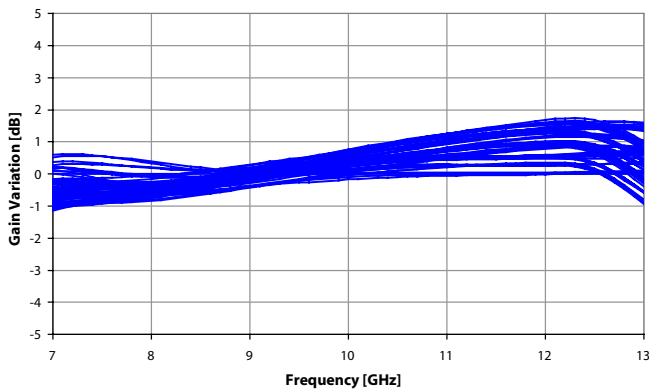

XS1000-BD, V_{ss}=-7.5V, All States

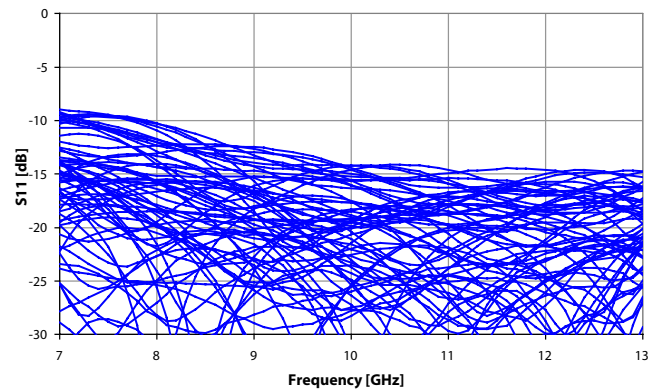

XS1000-BD, V_{ss}=-7.5V, All States

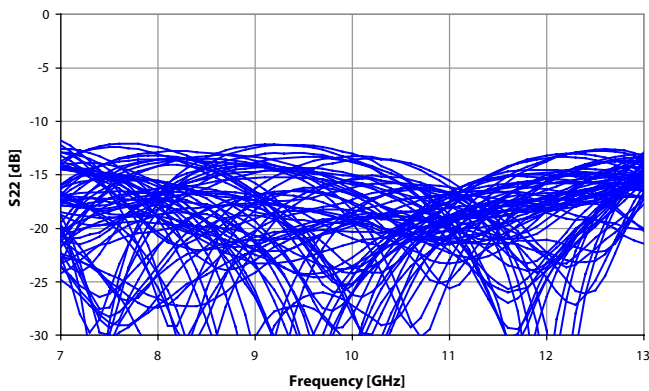

XS1000-BD, V_{ss}=-7.5V, All States

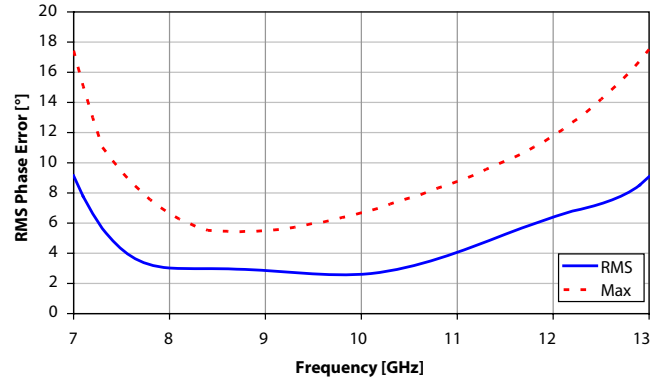

7.0-13.0 GHz GaAs MMIC 6-Bit Phase Shifter

Measurements (cont.)

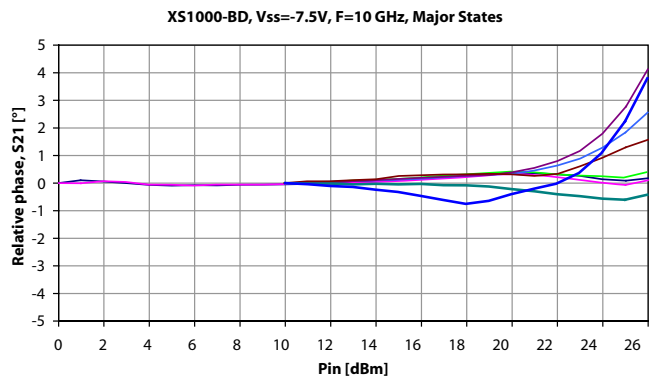
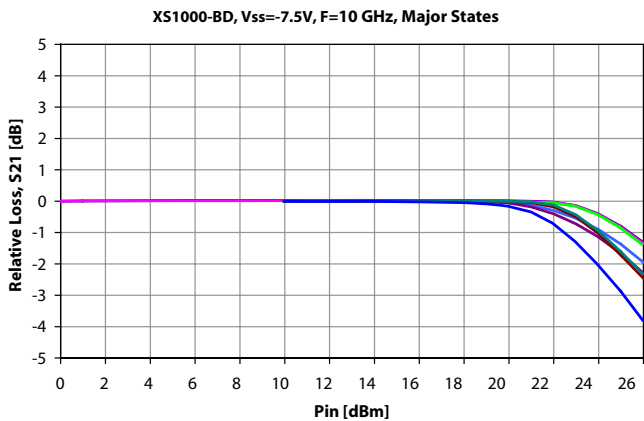
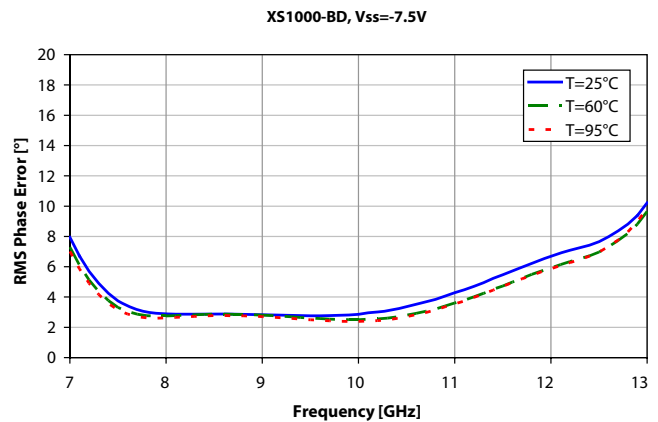
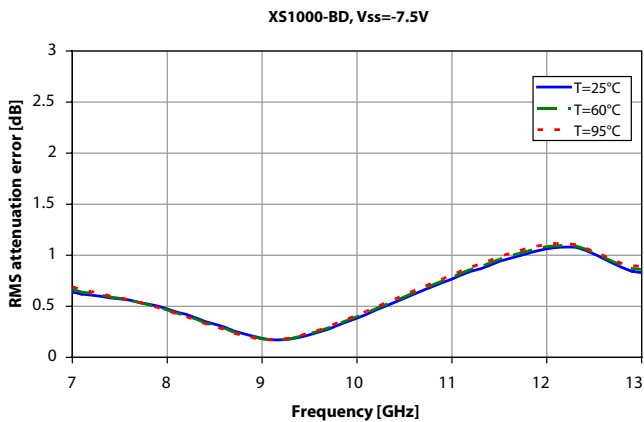
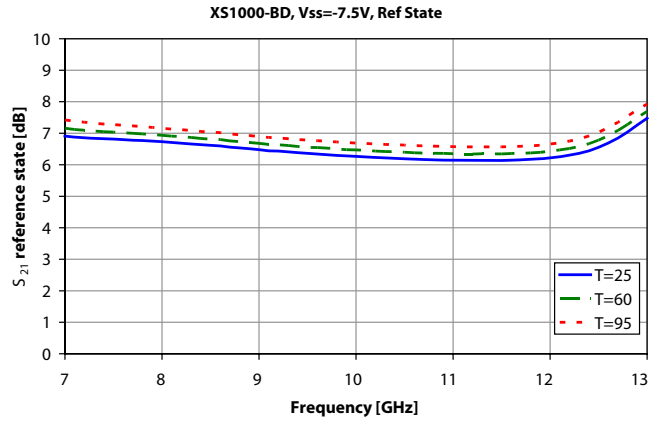
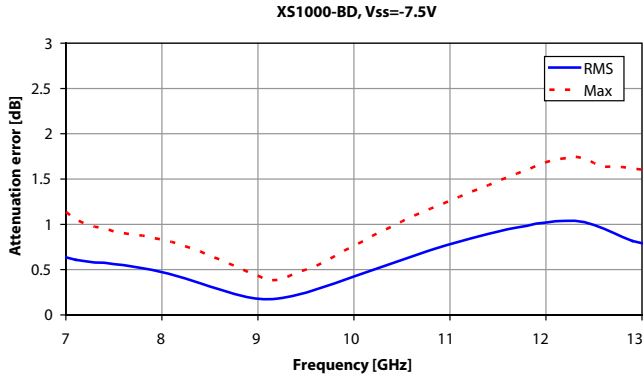

7.0-13.0 GHz GaAs MMIC 6-Bit Phase Shifter

Measurements (cont.)

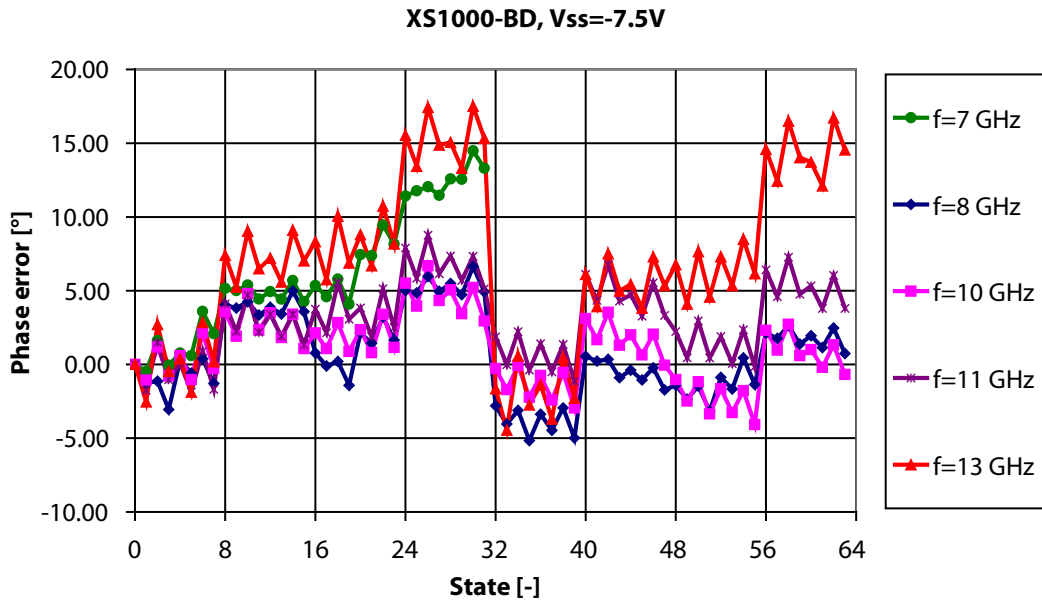

7.0-13.0 GHz GaAs MMIC 6-Bit Phase Shifter

Mechanical Drawing

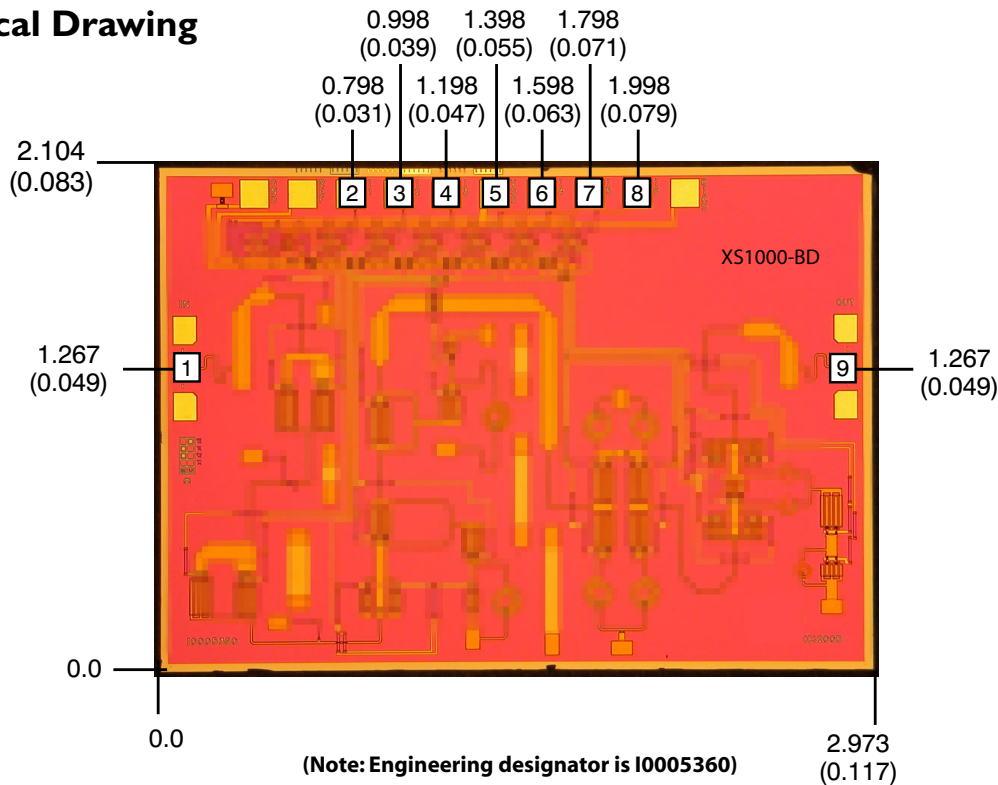

Units: millimeters (inches) Bond pad dimensions are shown to center of bond pad.
Thickness: 0.110 +/- 0.010 (0.0043 +/- 0.0004), Backside is ground, Bond Pad/Backside Metallization: Gold
All Bond Pads are 0.100 x 0.100 (0.004 x 0.004).
Bond pad centers are approximately 0.109 (0.004) from the edge of the chip.
Dicing tolerance: +/- 0.005 (+/- 0.0002). Approximate weight: 3.88 mg.

Bond Pad #1 (RF In)
Bond Pad #2 (Vc1)
Bond Pad #3 (Vc2)

Bond Pad #4 (Vc3)
Bond Pad #5 (Vss)

Bond Pad #6 (Vc4)
Bond Pad #7 (Vc5)

Bond Pad #8 (Vc6)
Bond Pad #9 (RF Out)

Bias Arrangement

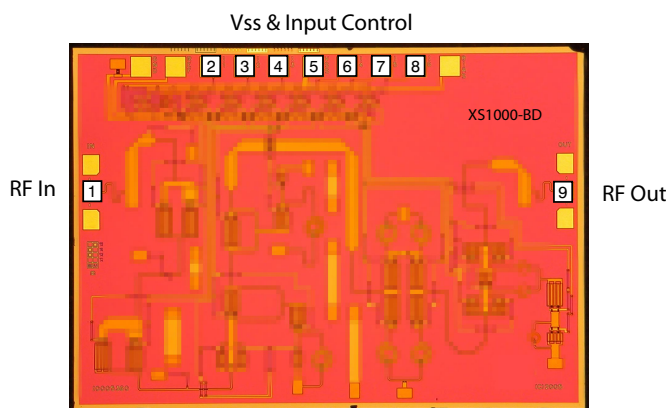

Bypass Capacitors - See App Note [2]

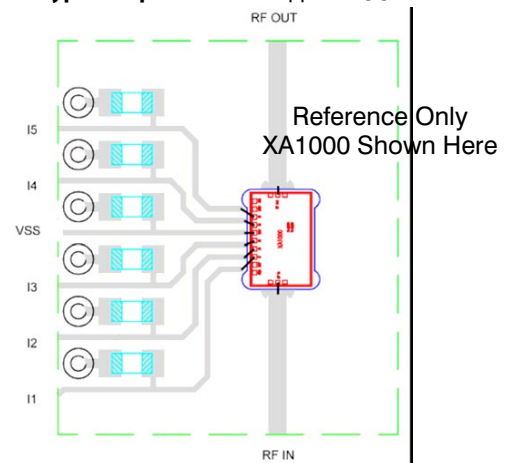

7.0-13.0 GHz GaAs MMIC 6-Bit Phase Shifter

May 2008 - Rev 28-May-08

App Note [1] Biasing - Logic buffering is integrated in the device to supply the necessary internal switching voltages. The reference state is enabled with logic "low" on all inputs, and the binary weighted phase(amplitude) states are switched by a logic "high" on the respective control input. Amplitude(phase) variation between phase(amplitude) states is minimised by optimisation of internal matching and isolation between bits. Each bit is controlled using a '0' for the reference state and a '1' for the enabled state.

Logic Truth Table - Major States

Phase Shift (degrees)	Vc1	Vc2	Vc3	Vc4	Vc5	Vc6
0°	0	0	0	0	0	0
5.625°	1	0	0	0	0	0
11.25°	0	1	0	0	0	0
22.5°	0	0	1	0	0	0
45°	0	0	0	1	0	0
90°	0	0	0	0	1	0
180°	0	0	0	0	0	1
354.375°	1	1	1	1	1	1

App Note [2] Bias Arrangement - Each DC/Control pad (Vss, Vc1-6) needs to have DC bypass capacitance (~100 pF) as close to the device as possible. Alternatively, place 100pF multi-layer ceramic capacitors close to the MMIC as shown on previous page. Choose decoupling capacitance and source resistance (if used) to provide adequate decoupling but not to impede dynamic switching performance of the application.

7.0-13.0 GHz GaAs MMIC 6-Bit Phase Shifter

May 2008 - Rev 28-May-08

Handling and Assembly Information

CAUTION! - Mimix Broadband MMIC Products contain gallium arsenide (GaAs) which can be hazardous to the human body and the environment. For safety, observe the following procedures:

- Do not ingest.
- Do not alter the form of this product into a gas, powder, or liquid through burning, crushing, or chemical processing as these by-products are dangerous to the human body if inhaled, ingested, or swallowed.
- Observe government laws and company regulations when discarding this product. This product must be discarded in accordance with methods specified by applicable hazardous waste procedures.

Life Support Policy - Mimix Broadband's products are not authorized for use as critical components in life support devices or systems without the express written approval of the President and General Counsel of Mimix Broadband. As used herein: (1) Life support devices or systems are devices or systems which, (a) are intended for surgical implant into the body, or (b) support or sustain life, and whose failure to perform when properly used in accordance with instructions for use provided in the labeling, can be reasonably expected to result in a significant injury to the user. (2) A critical component is any component of a life support device or system whose failure to perform can be reasonably expected to cause the failure of the life support device or system, or to affect its safety or effectiveness.

ESD - Gallium Arsenide (GaAs) devices are susceptible to electrostatic and mechanical damage. Die are supplied in anti-static containers, which should be opened in cleanroom conditions at an appropriately grounded antistatic workstation. Devices need careful handling using correctly designed collets, vacuum pickups or, with care, sharp tweezers.

Die Attachment - GaAs Products from Mimix Broadband are 0.100 mm (0.004") thick and have vias through to the back-side to enable grounding to the circuit. Microstrip substrates should be brought as close to the die as possible. The mounting surface should be clean and flat. If using conductive epoxy, recommended epoxies are Tanaka TS3332LD, Die Mat DM6030HK or DM6030HK-Pt cured in a nitrogen atmosphere per manufacturer's cure schedule. Apply epoxy sparingly to avoid getting any on to the top surface of the die. An epoxy fillet should be visible around the total die periphery. For additional information please see the Mimix "Epoxy Specifications for Bare Die" application note. If eutectic mounting is preferred, then a fluxless gold-tin (AuSn) preform, approximately 0.001" thick, placed between the die and the attachment surface should be used. A die bonder that utilizes a heated collet and provides scrubbing action to ensure total wetting to prevent void formation in a nitrogen atmosphere is recommended. The gold-tin eutectic (80% Au 20% Sn) has a melting point of approximately 280° C (Note: Gold Germanium should be avoided). The work station temperature should be 310°C +/- 10° C. Exposure to these extreme temperatures should be kept to minimum. The collet should be heated, and the die pre-heated to avoid excessive thermal shock. Avoidance of air bridges and force impact are critical during placement.

Wire Bonding - Windows in the surface passivation above the bond pads are provided to allow wire bonding to the die's gold bond pads. The recommended wire bonding procedure uses 0.076 mm x 0.013 mm (0.003" x 0.0005") 99.99% pure gold ribbon with 0.5-2% elongation to minimize RF port bond inductance. Gold 0.025 mm (0.001") diameter wedge or ball bonds are acceptable for DC Bias connections. Aluminum wire should be avoided. Thermo-compression bonding is recommended though thermosonic bonding may be used providing the ultrasonic content of the bond is minimized. Bond force, time and ultrasonics are all critical parameters. Bonds should be made from the bond pads on the die to the package or substrate. All bonds should be as short as possible.

Ordering Information

XS1000-BD-000V

RoHS compliant die packed in vacuum release gel paks



Proper ESD procedures should be followed when handling this device.

Mimix Asia, Inc. (a subsidiary of Mimix Broadband, Inc.)
3F, 3-2 Industry East IX Road, Science-Based Industrial Park • Hsinchu, Taiwan, R.O.C
Tel +886-3-567-9680 • Fax +886-3-567-9433 • mimixasia.com

Page 7 of 7